

## PADDY HUSKER



MODEL  
RH – Series

## SPECIFICATIONS

Model	RH20C	RH40C
Capacity (tons/hr)	1.5÷2	3÷4
Power (kW)	3	7.5
Speed of main shaft(rpm)	1005	1350
Power source	380V-50Hz	380V-50Hz
Type of feeding	Vibration	Vibration
Net weight (kg)	265	510
Gross weight (kg)	370	635
Dimension (LxWxH)	1100x500x1170	1075x720x1355

*Exclusively Distributed by:*

**GRAINSCO**

**Grains Innovation & Solutions Co., Inc.**

Manila Office: Unit 206 Veria Bldg.

62 West Avenue, Quezon City 1104 Philippines

✉ [info@grainsco.com](mailto:info@grainsco.com)

🌐 [www.grainsco.com](http://www.grainsco.com)

📘 [facebook.com/Grainsco](https://facebook.com/Grainsco)

**CUSTOMER CARE HOTLINES:**

**FARM MACHINERY:** 0917 103-8888 / 0919 088-8883

**GRAIN PROCESSING:** 0917 101-8888 / 0917 102-8888 / 0919 088-8881

## PADDY HUSKER

### FEATURES AND FUNCTIONS

- It uses husking chaff out of paddy.
- There is a cooling fan for rubber roller, so working efficiency of rolling rubber increase.
- Easy to assemble/disassembled or to replace rubber rollers.
- Auto-pressing of rubber rolls by hanging weight structure.
- Driving by belt, so it works smoothly and easy for replacing and maintaining.
- Especially, two shafts of rubber roller are put in tilt and combine with grain guiding chute.
- Husking efficiency > 90%
- Broken rate < 3%
- Low cost of power.
- Low cost of rubber roller.

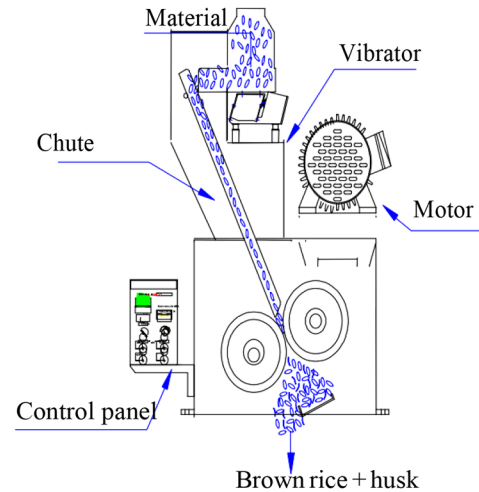

### OVERALL DIMENSIONS

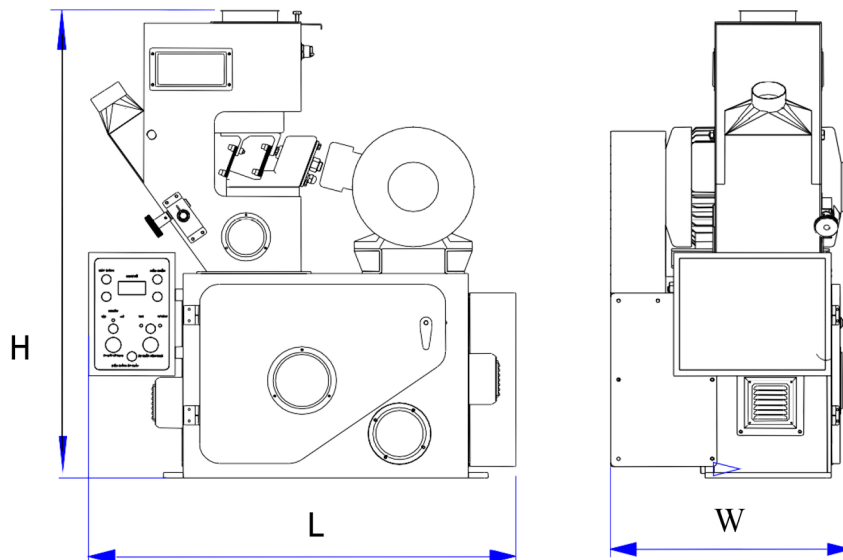

**Exclusively Distributed by:**

## GRAINSCO

**Grains Innovation & Solutions Co., Inc.**

Manila Office: Unit 206 Veria Bldg.  
62 West Avenue, Quezon City 1104 Philippines

**CUSTOMER CARE HOTLINES:**

**FARM MACHINERY:** 0917 103-8888 / 0919 088-8883

**GRAIN PROCESSING:** 0917 101-8888 / 0917 102-8888 / 0919 088-8881

✉ [info@grainsco.com](mailto:info@grainsco.com)

🌐 [www.grainsco.com](http://www.grainsco.com)

📘 [facebook.com/Grainsco](https://facebook.com/Grainsco)